

—
INSTALLATION AND OPERATING INSTRUCTION

Motorized change-over and transfer switches

OTM_C

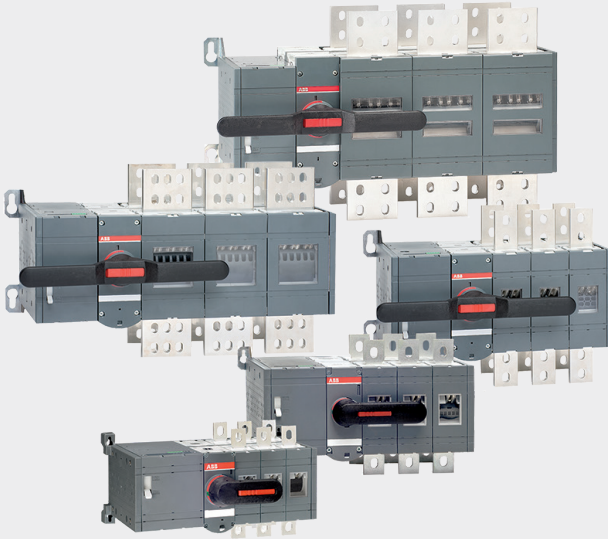
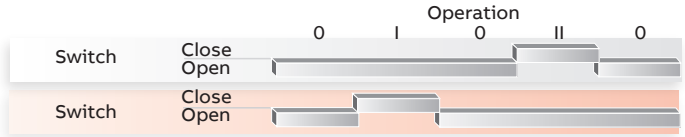
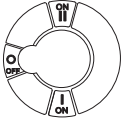

Table of contents

1.	Introduction	04
1.1	Use of symbols	04
1.2	Explanations of abbreviations and terms	04
2.	Product overview	05
3.	Quick start	06
3.1	Operating the motorized change-over witch electrically: remote control	06
3.1.1	Locking electrical operation	07
3.2	Operating the motorized cahnge over switch manually; local operation	08
4.	Installation	09
4.1	Mounting the motorized change-over switch	09–10
5.	Dimension drawings	11–17
6.	Connections	18
6.1	Mounting postitions	19
6.2	Labelling	19
7.	Connecting	20
8.	Operating	21
8.1	Electrical operation	21–22
8.1.1	Impulse control	23
8.1.2	Continuous control	24
8.2	Manual operation by using the handle	25
8.3	Locking	26
8.3.1	Locking the electrical operation	26
8.3.2	Locking the manual operation	26–27
9.	Technical data	28–29
10.	Accessories	30
10.1	Terminal clamp sets OZXA_OTZB_	30
10.2	Bridging bars OTZC_, OTZR_	31–34
10.3	Voltage sensing connectors OMZB_	35
10.4	Terminal shrouds OTS_	36–37
10.5	Reversing bars OTZR_	38
10.6	Voltage sensing connectors OMZB_	39–40
10.7	Auxiliary contacts OA_	41
10.8	Dual power source ODPS_	42
10.9	Handle and spare fuse storage OTVS_	43
11.	Clearances per UL 1008	44
11.1	Phase barriers OTB_	45–46

Operation

OTM_C



OTM_CL

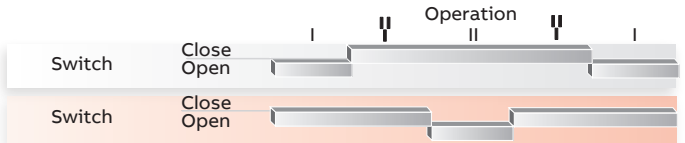
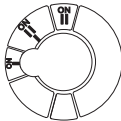

OTM_CF

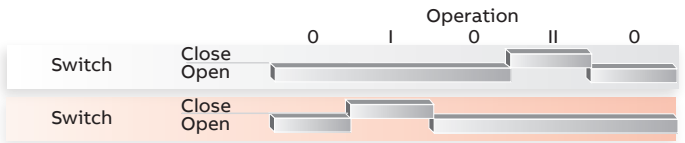
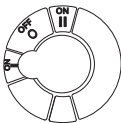

1. Introduction

This manual describes the installation and the basic operation of the motorized change-over and transfer switches, types OTM_C. The instructive part is followed by a section on available accessories.

1.1 Use of symbols



Hazardous voltage: warns about a situation where a hazardous voltage may cause physical injury to a person or damage to equipment.



General warning: warns about a situation where something other than electrical equipment may cause physical injury to a person or damage to equipment.



Caution: provides important information or warns about a situation that may have a detrimental effect on equipment.



Information: provides important information about the equipment.

1.2 Explanations of abbreviations and terms

OTM_C:	Motorized change-over switch, the type name
OME_:	Motor operator, the type name
OT_C:	Change-over switch, the type name
OZXB_ and OZXA_:	Terminal clamp sets, the type name, accessories
OTZC_:	Bridging bars, the type name, accessories
OTS_:	Terminal shrouds, the type name, accessories
OA_:	Auxiliary contacts, the type name, accessories
ODPS_:	Dual power source, the type name, accessories

2. Product overview

Motorized change-over switches (type OTM_C) are suitable for remote control. You can operate the motorized change-over switches either electrically by using the motor operator or manually by using the handle. The operation, either electrical or manual, can be chosen by the selector switch “Motor/ Manual” on the motor operator. Motorized change-over switches consist of the change-over switch and the motor operator.

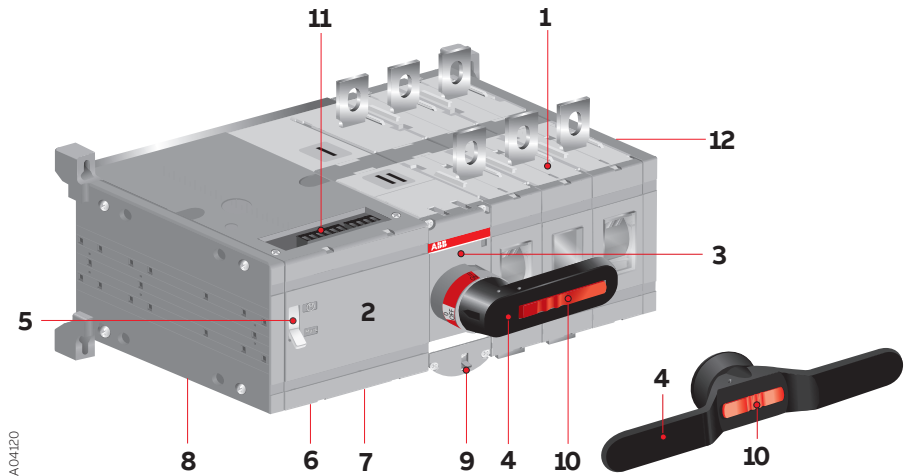

Figure 2.1 Motorized change-over switch (type OTM_C)

- 1 Change-over switch
- 2 Motor operator
- 3 Switch panel, the operating mechanism
- 4 Handle for manual operation, double grip handle in sizes OTM1000-3200_C
- 5 Motor/Manual selection
- 6 Terminals for motor operator voltage supply
- 7 Terminals for push-buttons
- 8 Fuse (F1) of motor operator
- 9 Locking latch for releasing the handle and locking electrical operation
- 10 Locking clip for locking manual operation
- 11 Terminals for locking state information
- 12 Place for auxiliary contacts

3. Quick start

This is a quick guide only meant for those who need a reminder of how to operate the unit.
For more detailed instructions, see chapter 6.

3.1 Operating the motorized change-over switch electrically; remote control

To operate the motorized change-over switch electrically:

1. Remove the handle from the switch panel. You can remove the handle in all positions (I, 0, II).
2. Turn the Motor/Manual selector to the Motor (M) position to enable electrical operation.

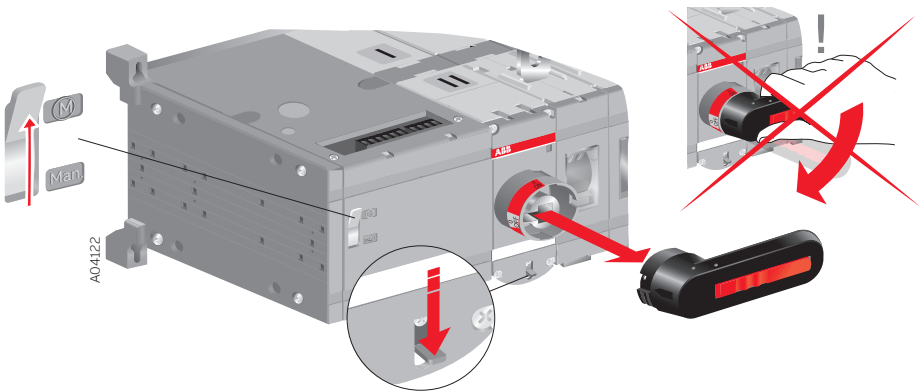

Figure 3.1 Operating the motorized change-over switch electrically; remote control

3.1.1 Locking electrical operation

To disable electrical operation, lock the locking latch with a padlock. After the locking latch has been locked, the motorized change-over switch cannot be operated electrically. You can lock electrical operation in all positions (I, 0, II).

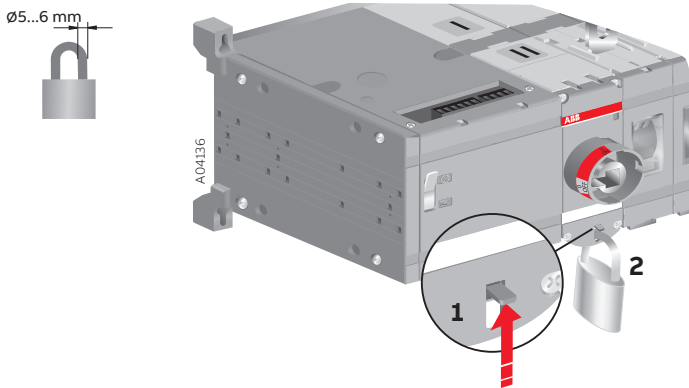
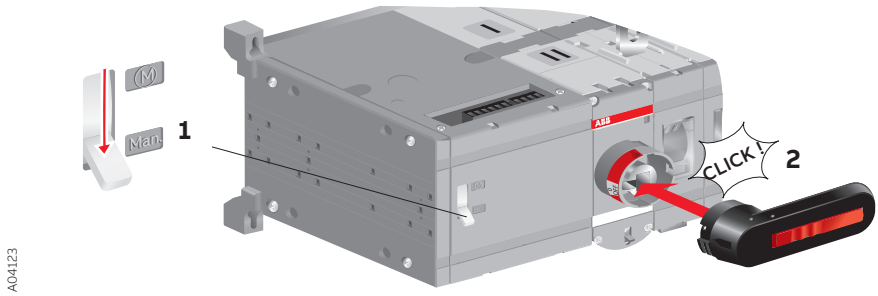

Figure 3.2 Locking electrical operation

3.2 Operating the motorized change-over switch manually; local operation

To operate the motorized change-over switch manually:

1. Turn the Motor/Manual selector to the Manual (Man.) position to enable manual operation and to prevent electrical operation.
2. Attach the handle to the switch panel. You can attach the handle in all positions (I, 0, II).



A04123

Figure 3.3 Operating the motorized change-over switch manually

To disable the manual (and at the same time also electrical) operation, lift up the locking clip to position 0 and attach the padlock to the handle.



A04137

Figure 3.4 Locking the manual operation

4. Installation

4.1 Mounting the motorized change-over switch



Caution

Use protection against direct contact.

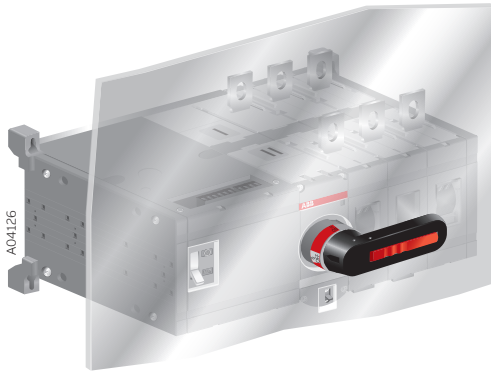
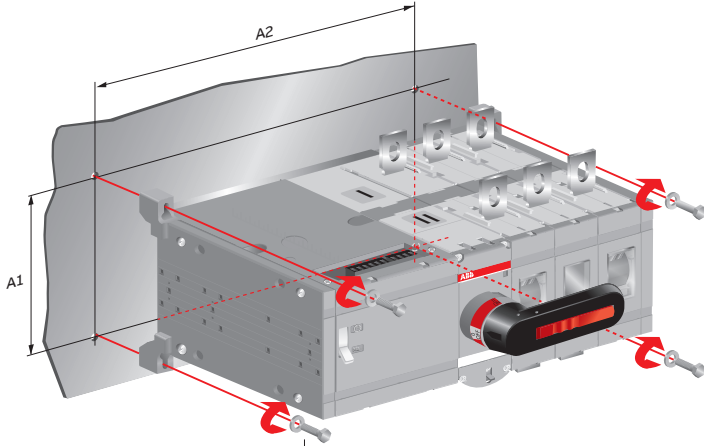

Figure 4.1 An example of using protection against direct contact



	M5		M6		M10	
	3,5...4 Nm 31...35.4 lb.in					
	OTM160-250_C_		OTM600-800E_C_		OTM800-1200U_C_	
	OTM315_400_C_				OTM1000-2500_C_	
					OTM3200_C_	

	OTM160-250_C_M		OTM160-250_WC_M		OTM200_C_M	
	E3	E4	E3	E4	U3	U4
A1	116	116	116	116	116/4.57	116/4.57
A2	258	293	282	325	282/11.10	325/12.80

	OTM315-400_C_M		OTM400_C_M	
	E3	E4	U3	U4
A1	142	142	142/5.59	142/5.59
A2	305	349	335/13.19	389/15.31

	OTM630-800_C_M		OTM600_C_M	
	E3	E4	U3	U4
A1	180	180	180/7.09	180/7.09
A2	390	455	390/15.35	455/17.91

	OTM1000-1250_C_M		OTM1600_WC_M		OTM800-1200_C_M	
	E3	E4	E3	E4	U3	U4
A1	230	230	230	230	230/9.06	230/9.06
A2	476,5	556,5	476,5	556,5	476,5/18.77	556,5/21.92

	OTM2000-2500_C_M	
	E3	E4
A1	230	230
A2	614,5	740,5

	OTM3200-4000_C_M	
	E3	E4
A1	250	250
A2	661,5	801,5

AO4127

Figure 4.2 Motorized change-over switches, drilling hole distances / screw-mounting, [mm/in]

5. Dimension drawings

OTM160-250E_C_M, OTM160-250E_WC_M

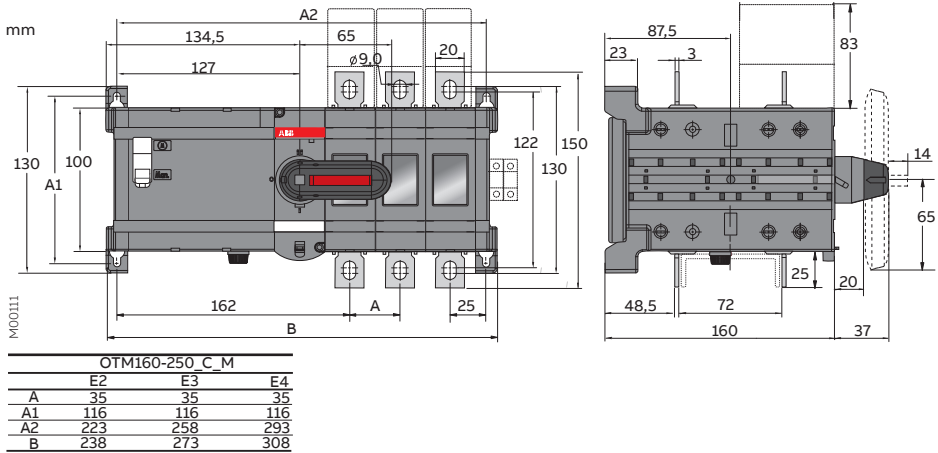

Figure 5.1 OTM160-250E_C_M

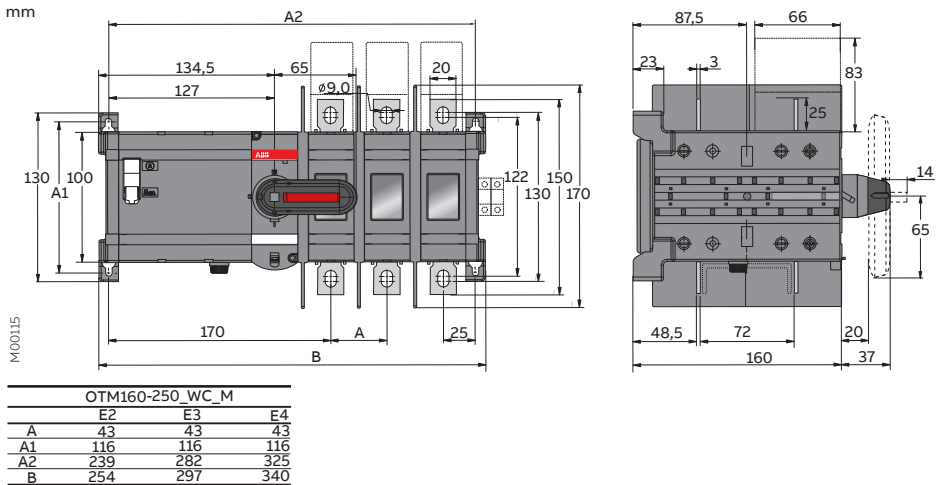

Figure 5.2 OTM160-250E_WC_M

Dimension drawings

OTM200U_C_M, OTM315-400E_C_M

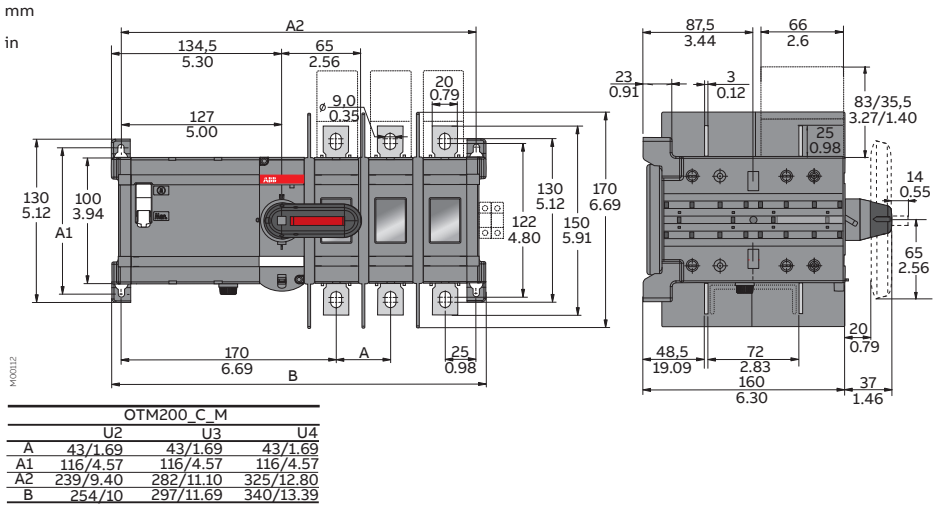

Figure 5.3 OTM200U_C_M

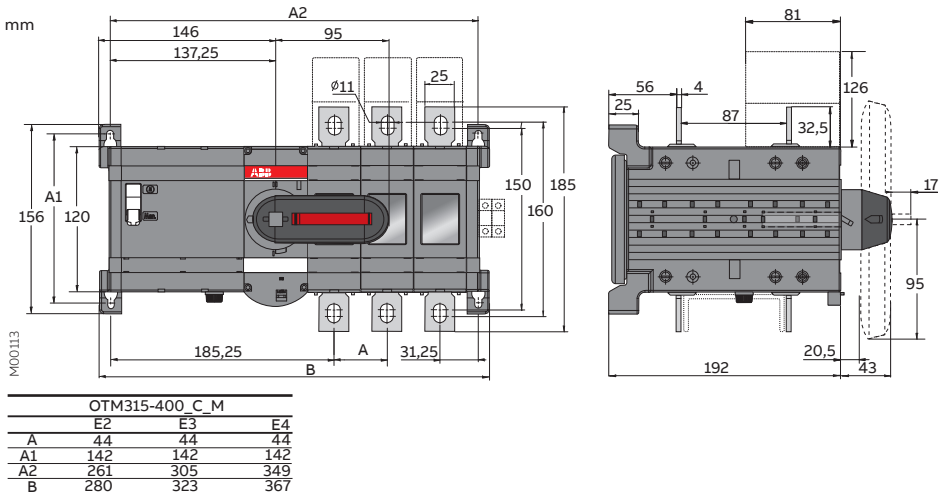

Figure 5.4 OTM315-400E_C_M

Dimension drawings

OTM315-400E_WC_M, OTM400U_C_M

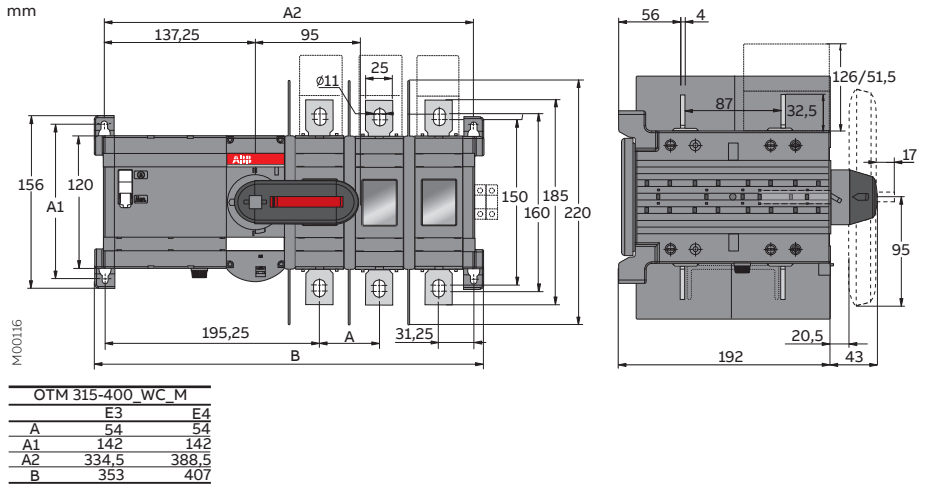

Figure 5.5 OTM315-400E_WC_M

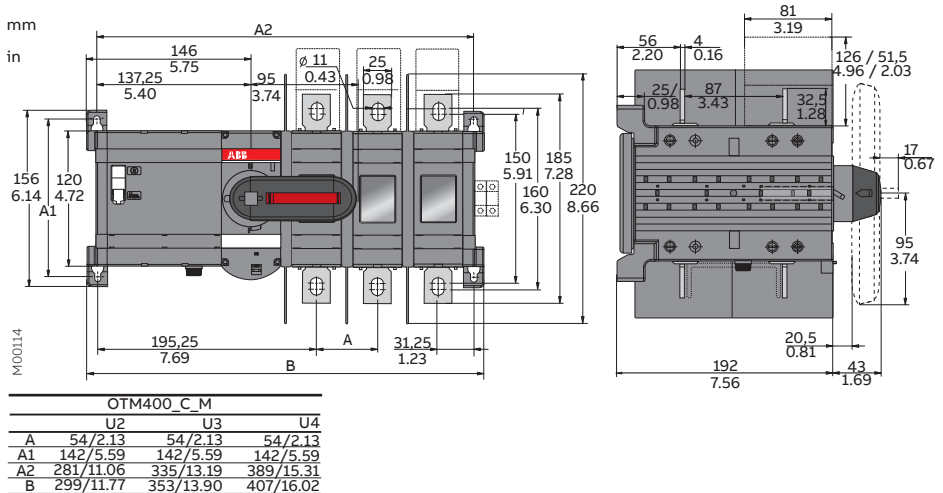

Figure 5.6 OTM400U_C_M

Dimension drawings

OTM630-800E_C_M, OTM600U_C_M

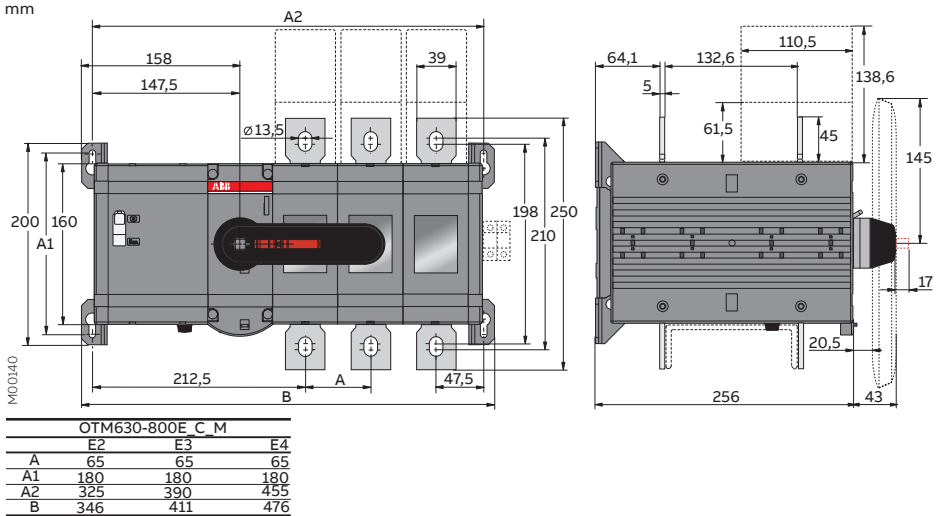

Figure 5.7 OTM630-800E_C_M

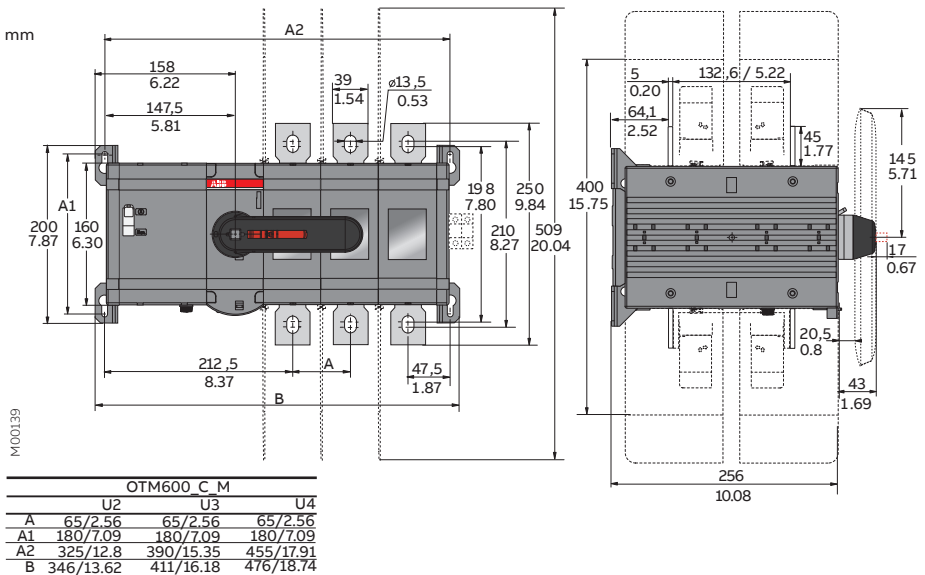
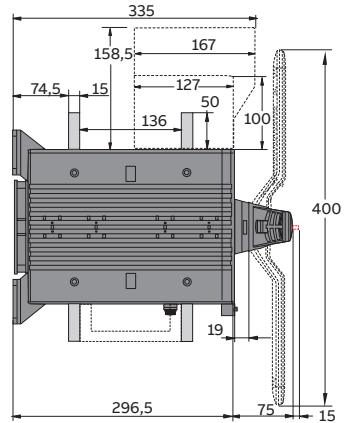
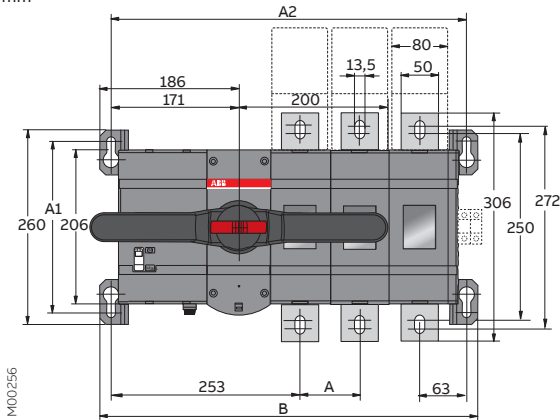

Figure 5.8 OTM600U_C_M

Dimension drawings

OTM1000-1200E_C_M, OTM1600E_C_M

mm



M00256

OTM1000-1250_C_M			
	E2	E3	E4
A	80	80	80
A1	230	230	230
A2	396,5	476,5	556,5
B	426,5	506,5	586,5

Figure 5.9 OTM1000-1200E_C_M

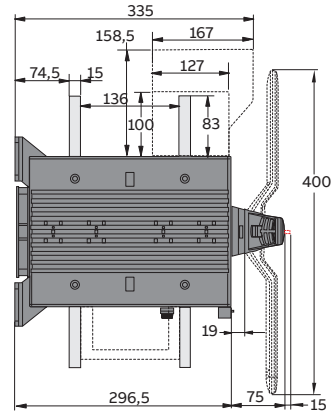
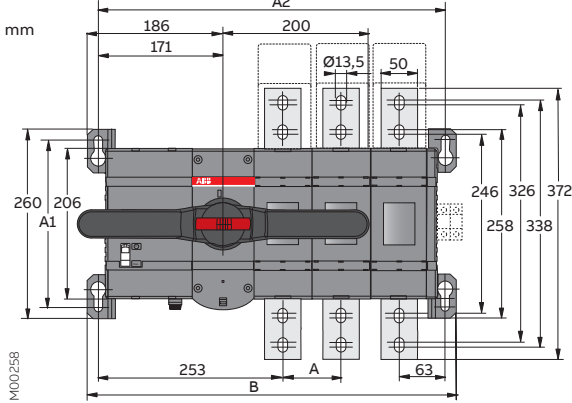

M00258

OTM1600_C_M			
	E2	E3	E4
A	80	80	80
A1	230	230	230
A2	396,6	476,5	556,5
B	426,5	506,5	586,5

Figure 5.10 OTM1600E_C_M

Dimension drawings

OTM800-1200U_C_M

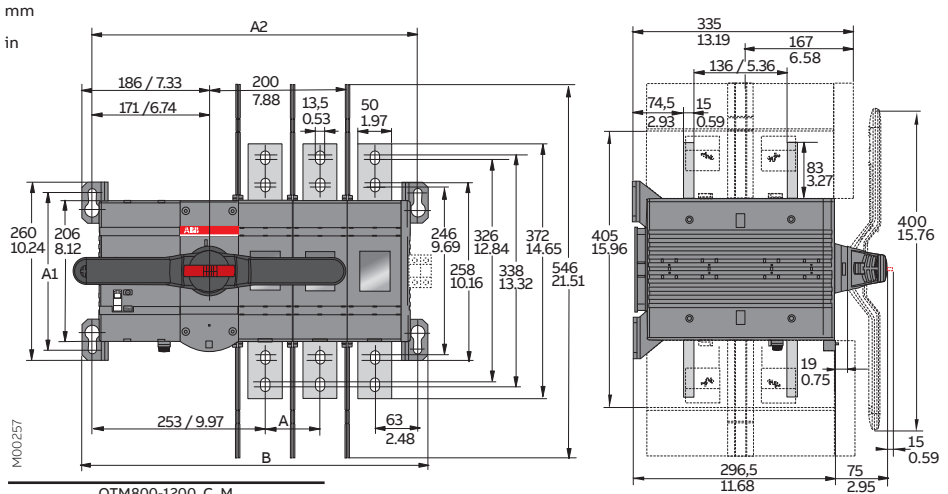

OTM800-1200_C_M			
	U2	U3	U4
A	80/3.15	80/3.15	80/3.15
A1	230/9.06	230/9.06	230/9.06
A2	396,5/15.62	476,5/18.77	556,5/21.92
B	426,5/16.8	506,5/19.96	586,5/23.11

Figure 5.11 OTM800-1200U_C_M

Dimension drawings

OTM2000-2500E_C_M, OTM3200_C_M

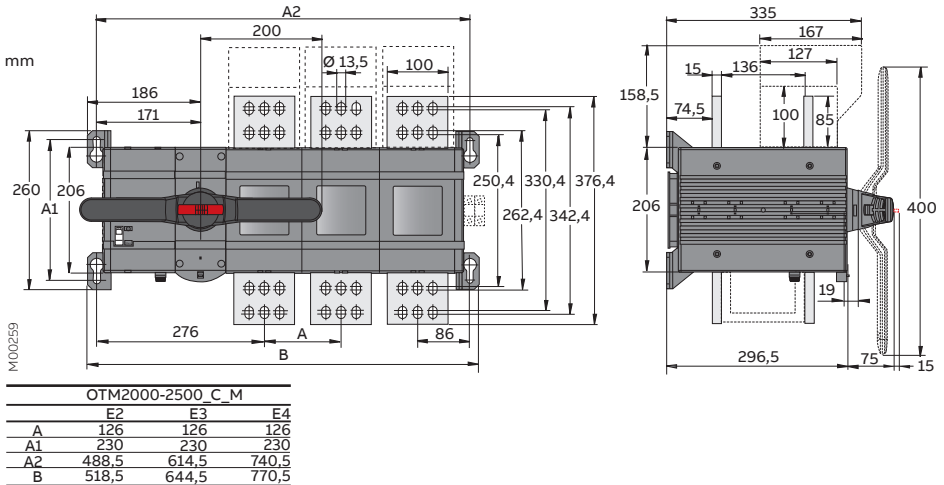

Figure 5.12 OTM2000-2500E_C_M

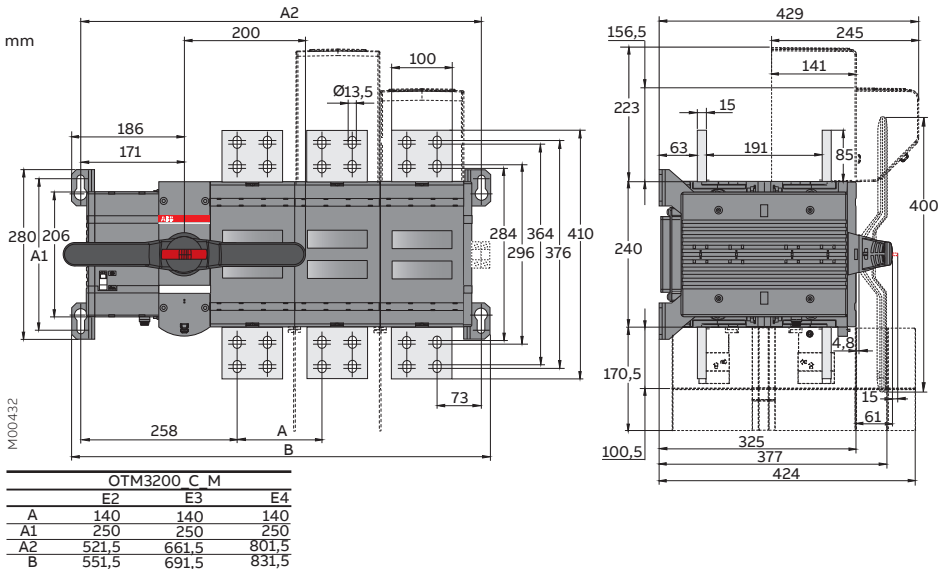

Figure 5.13 OTM3200_C_M

6. Connections

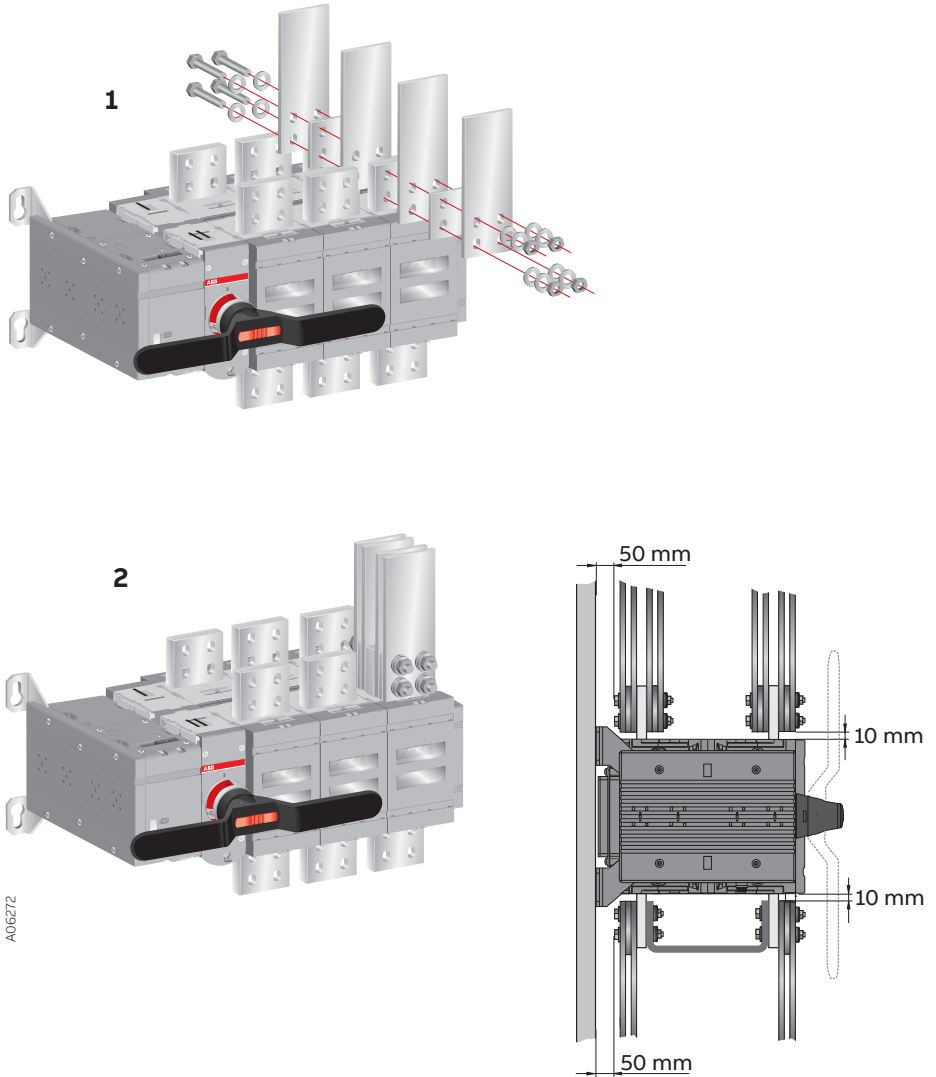

Figure 6.1 Mounting the connections to the motorized change-over switches OTM3200_C_M

6.1 Mounting positions

The recommended mounting positions for motorized change-over switches are horizontal, wall mounted or table mounted.

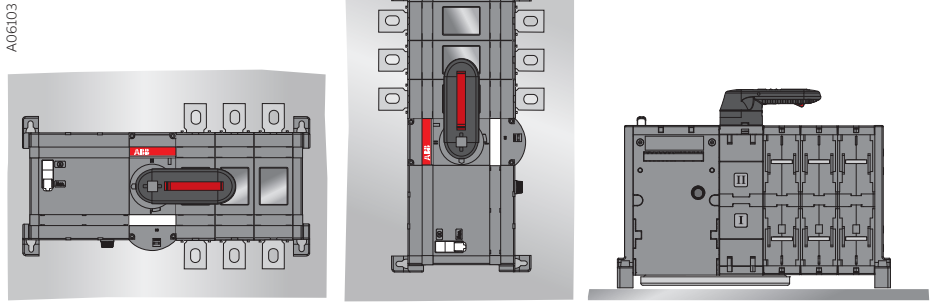

Figure 6.2 Mounting positions



Information

Do not install the motorized change-over switches in any other position than those described above.

6.2 Labelling

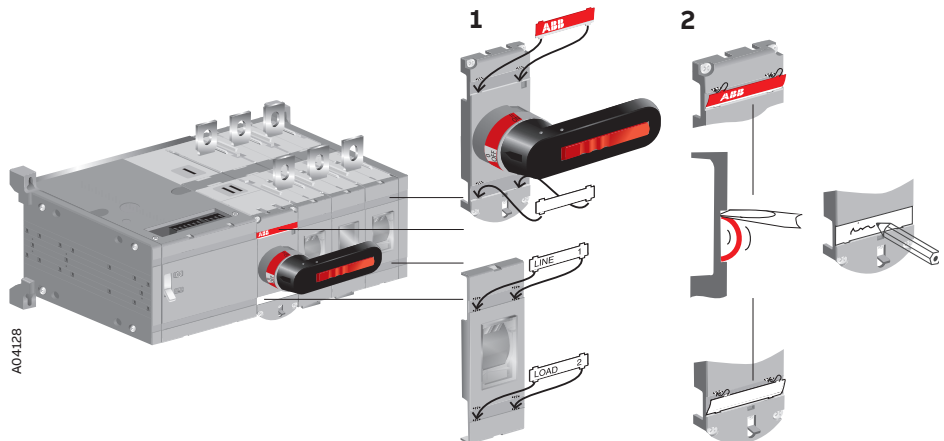

Figure 6.3 Labelling of the motorized change-over switches

7. Connecting



Warning

Only an authorised electrician may perform the electrical installation and maintenance of motorized change-over switches. Do not attempt any installation or maintenance actions when a motorized change-over switch is connected to the electrical mains. Before starting work, make sure that the change-over switch is de-energised.

7.1 Control circuit

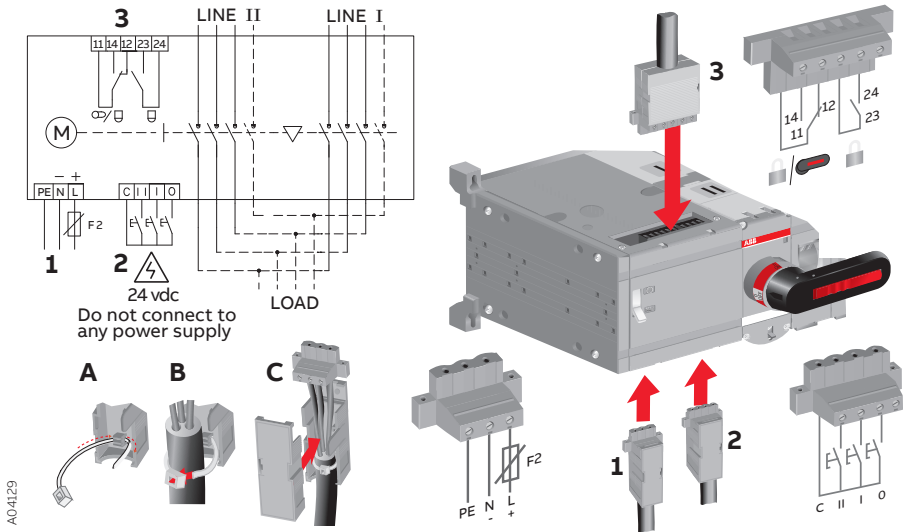

Figure 7.1 Motorized change-over switch terminals

1. Terminal for motor operator voltage supply
2. Control terminal for push buttons or selector switch
3. Terminal for state information of locking



Information

Do not couple power for the control terminal. See the correct terminal for the power supply in Figure 7.1



Hazardous voltage

The control voltage (output C = 24Vdc) on the control terminal is non-isolated, see box 2 in Figure 7.1



Warning

When relay outputs are used with inductive loads (such as relays, contactors and motors), they must be protected from voltage spikes using varistors, RC-protectors (AC current) or DC current diodes (DC current).

8. Operating



Hazardous
warning

Never open any covers on the product. There may be dangerous external control voltages inside the motorized change-over switch even if the voltage is turned off.



Never handle control cables when the voltage of the motorized change-over switch or external control circuits are connected.



Exercise sufficient caution when handling the unit.

8.1 Electrical operation

The motorized change-over switches are available for remote control.

To operate the motorized change-over switch electrically:

1. Release the handle from the switch panel by pressing down the locking latch under the switch panel and pulling the handle off, see Figure 8.1.

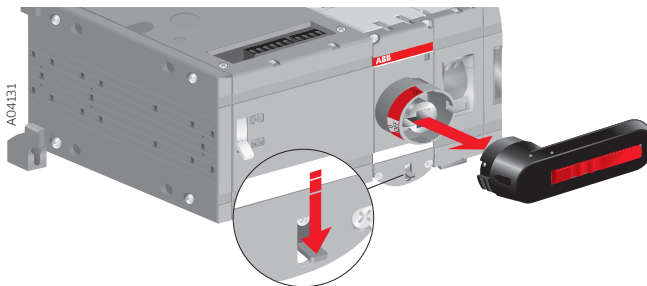

Figure 8.1 Releasing the handle



Information

Electrical operation is disabled if the handle is attached to the switch panel.

- 2. Turn the Motor/Manual selection switch to the Motor (M) position, see Figure 8.2.

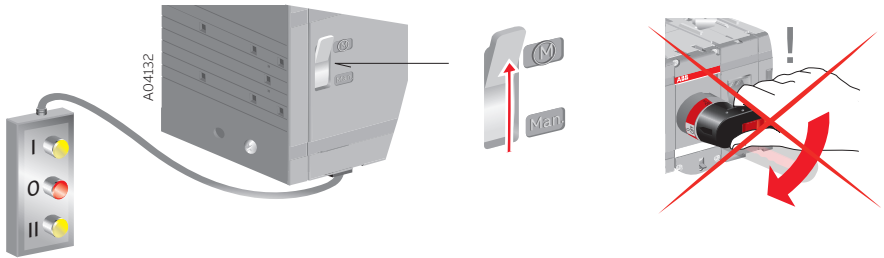

Figure 8.2 Motor/Manual selection switch in the Motor (M) position

- 3. Operate the motorized change-over switch with the push-buttons or selector switch via impulse control or continuous control.



Information

The motor operator is protected from overloading by a fuse (F1) under the motor operator. Only use the same type of fuse that is described on the label close to the fuse.

8.1.1 Impulse control

When using impulse control, the change-over switch is operated by electric impulses. When you press the control button, the change-over switch is driven to the corresponding position (I, 0, II). The control impulse must last more than 100ms to take effect. A new command cannot be given until the change-over switch has reached the position of the previous command. Figure 8.3 shows the operation of the change-over switch with impulse control.



Information

If a new command is given before the switch has reached the position of the previous command, the fuse (F1) may operate.

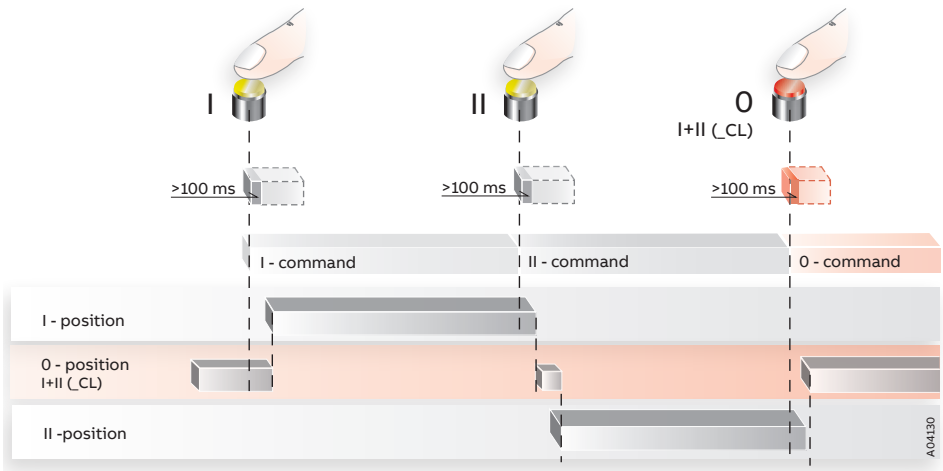

Figure 8.3 Impulse control

3. Operate the motorized change-over switch with the push-buttons or selector switch via impulse control or continuous control.

8.1.2 Continuous control

When using continuous control, the control command is supplied to the switch continuously. When you press the control button, the change-over switch is driven to the corresponding position (I, 0, II). Operation of position 0 will over-run control of the other positions; that is, if you simultaneously give the 0 command with another command, the change-over switch is driven to position 0. Figure 8.4 shows the operation of the change-over switch with continuous control.



Information

The continuous control command can be given with push buttons, cam switches or with relays incorporated in PLC equipment or with other suitable contacts.

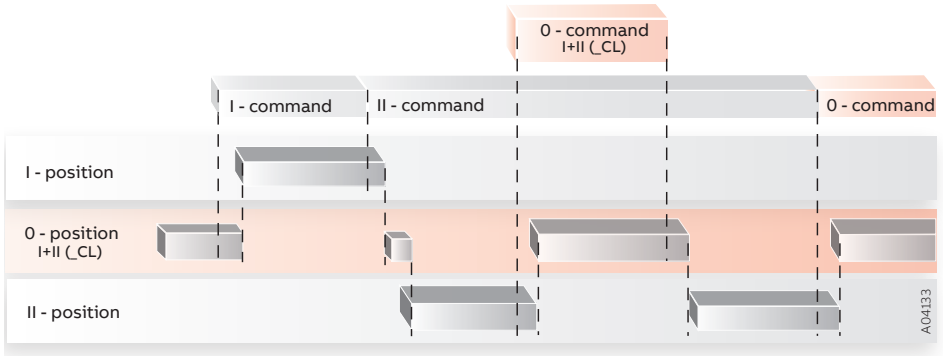

Figure 8.4 Continuous control

8.2 Manual operation by using the handle

You can operate the motorized change-over switch manually by using the handle that is included in the delivery. To operate the motorized change-over switch manually:

1. Turn the Motor/Manual selector to the Manual (Man.) position, see Figure 8.5. The motor operator is switched off and electrical operation is prevented.

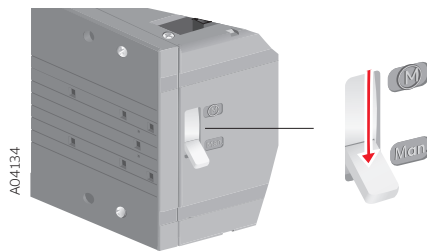

Figure 8.5 Motor/Manual selection in the Man. position

2. Attach the handle by pressing it to the switch panel until it clicks into place. You can attach the handle in all positions (I, 0, II), see Figure 8.6.

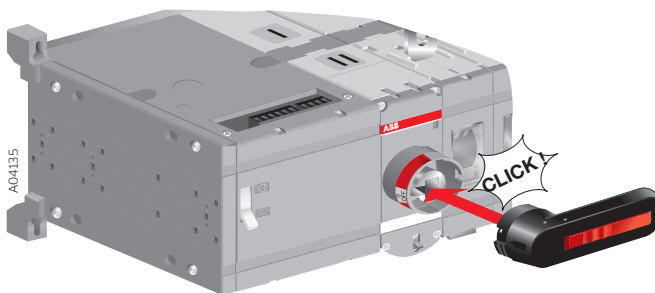

Figure 8.6 Attaching the handle

3. Operate the motorized change-over switch by turning the handle to the required position (I, 0, II).



Information

Electrical operation is prevented when the handle is attached to the switch panel.

8.3 Locking

You can lock the motorized change-over switch to a specific position.

8.3.1 Locking the electrical operation

To disable electrical operation, lock the locking latch with a padlock. After the locking latch has been locked, the change-over switch cannot be operated electrically. You can lock the electrical operation in all positions (I, 0, II).

To lock electrical operation:

1. Pull up the locking latch under the change-over switch panel.
2. Place the padlock under the latch, see Figure 8.7.

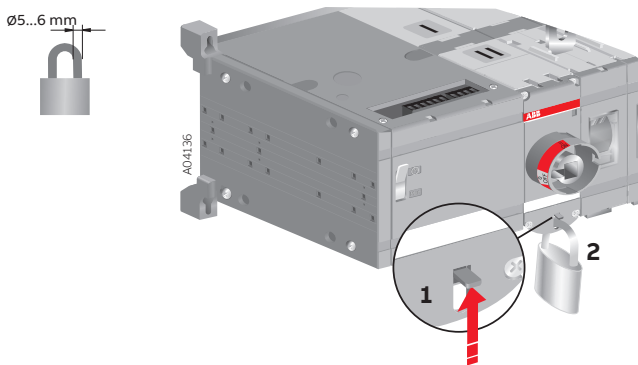

Figure 8.7 Locking the electrical operation



Information

The handle cannot be attached when electrical operation is locked.

8.3.2 Locking the manual operation

By default, manual operation can only be locked to position 0. Locking to position I and II is optional and possible only with modifications to the switch panel.

To lock manual operation:

1. Turn the handle to the required position.
2. Pull out the clip from the handle and place the padlock on the handle; see Figure 8.8



Figure 8.8 Locking the manual operation



The handle cannot be removed when padlocked to position 0.

Information

The following figure shows the locking state information (the voltage on motor operator supply needed).

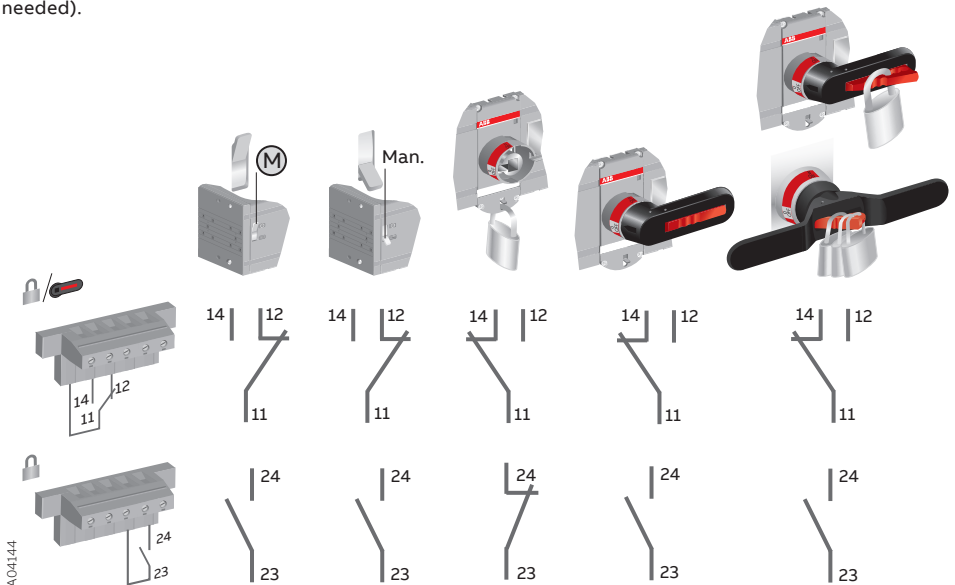

Figure 8.9 Locking state information

9. Technical data

Motor operator, control circuit	Value	Cabling
Rated operational voltage U [V]	220-240 Vac 50-60 Hz	
	110-125 Vac/dc 50-60 Hz	
	48 Vdc	
	24 Vdc	
Operating voltage range	0.85... 1.1 x U	
Operating angle	90° 0-I, I-0, 0-II, II-0; 180° I-0-II	
Operating time	See the Table 7.2	
Protection degree	IP 20, front panel	
Rated impulse withstand voltage U _{imp}	4 kV	
Voltage supply	PE N L	1,5 -2,5 mm ²
F2	Max. MCB 16 A	
Cable of the push-buttons (no SELV)	C II I 0	1,5 -2,5 mm ²
Maximum cable length	100 m	
State information of locking (no SELV)		
Handle attached or motor operator locked	11-12-14 (C/O)	1,5 -2,5 mm ²
Locking motor operator	23-24 (NO)	1,5 -2,5 mm ²
Operating temperature	-25... +55 °C	
Transportation and storage temperature	-40... +70 °C	
Altitude	Max. 2000 m	

Table 9.1 **General technical data of motor operators**

Type	Voltage U_e	Nominal current ^{a)} I_n	Current Inrush ^{a)}	Operating time ^{a)} I-0, 0-I, 0-II, II-0	Operating transfer time ^{a)} I-II or II-I	Contact transfer time ^{a)} I-II or II-I	Fuse 5 x 20 mm 250 V
	[V]	[A]	[A]	[s]	[s]	[s]	
OTM160...250_C	220-240 Vac	0,2	1,3	0,4 - 1,0	1,0 - 2,0	0,4 - 1,0	T 315 mA
OTM160...250_C	110-125 Vac/dc	0,45	2,1	0,5 - 1,2	1,1 - 2,5	0,5 - 1,1	T 500 mA
OTM160...250_C	48 Vdc	1,1	4,4	0,5 - 1,2	1,1 - 2,5	0,5 - 1,1	T 1,25 mA
OTM160...250_C	24 Vdc	3,3	16,8	0,5 - 1,0	1,0 - 2,0	0,4 - 1,0	T 4 AH
OTM315...400_C	220-240 Vac	0,5	2,1	0,4 - 1,0	0,9 - 2,0	0,4 - 1,0	T 500 mA
OTM315...400_C	110-125 Vac/dc	0,6	2,5	0,5 - 1,5	1,2 - 2,6	0,5 - 1,5	T 630 mA
OTM315...400_C	48 Vdc	2,1	8,3	0,4 - 1,0	1,0 - 2,0	0,4 - 1,0	T 2,5 AH
OTM315...400_C	24 Vdc	4,2	17,5	0,4 - 1,0	1,0 - 2,0	0,4 - 1,0	T 4 AH
OTM600...800_C	220-240 Vac	0,7	2,8	0,4 - 1,0	0,9 - 2,0	0,4 - 1,0	T 1 AH
OTM600...800_C	110-125 Vac/dc	0,8	4,6	0,6 - 1,5	1,2 - 3,0	0,6 - 1,5	T 1 AH
OTM600...800_C	48 Vdc	2,6	8,4	0,6 - 1,6	1,2 - 3,0	0,6 - 1,6	T 2,5 AH
OTM600...800_C	24 Vdc	4,0	22,4	0,5 - 1,5	1,1 - 2,5	0,5 - 1,5	T 5 AH
OTM1000...1600_C	220-240 Vac	1,8	7,7	0,5 - 1,5	1,5 - 3,0	0,5 - 1,5	T 2 AH
OTM1000...1600_C	110-125 Vac/dc	3,0	13,3	0,5 - 1,5	1,5 - 3,0	0,5 - 1,5	T 4 AH
OTM1000...1600_C	48 Vdc	5,3	22,4	0,5 - 1,5	1,5 - 3,0	0,5 - 1,5	T 5 AH
OTM1000...1600_C	24 Vdc	8,0	26,6	1,0 - 2,0	2,0 - 3,5	0,8 - 1,7	T 10 AH
OTM2000...2500_C	220-240 Vac	1,8	7,7	0,5 - 2,0	1,5 - 3,5	0,5 - 1,5	T 2 AH
OTM2000...2500_C	110-125 Vac/dc	3,0	13,3	0,5 - 2,0	1,5 - 3,5	0,5 - 1,5	T 4 AH
OTM2000...2500_C	48 Vdc	5,3	22,4	0,5 - 2,0	1,5 - 3,5	0,5 - 1,5	T 5 AH
OTM2000...2500_C	24 Vdc	8,0	26,6	1,0 - 2,0	2,0 - 3,5	0,8 - 1,7	T 10 AH
OTM3200_C	220-240 Vac	1,8	7,7	0,5 - 2,0	1,5 - 3,5	0,5 - 1,5	T 2 AH
OTM3200_C	110-125 Vac/dc	3,0	13,3	0,5 - 2,0	1,5 - 3,5	0,5 - 1,5	T 4 AH
OTM3200_C	48 Vdc	5,3	22,4	0,5 - 2,0	1,5 - 3,5	0,5 - 1,5	T 5 AH
OTM3200_C	24 Vdc	8,0	26,6	1,0 - 2,0	2,0 - 3,5	0,8 - 1,7	T 10 AH

a) Under nominal conditions

Table 9.2 Specified technical data of motor operators

Measurement	Value
Handle attached or motor operator locked	11-12-14 (C/O): 5 A AC-1 / 250 V
Locking motor operator	23-24 (NO): 5 A AC-1 / 250 V
SCPD	Max. MCB C2A

Table 9.3 State information

10. Accessories

10.1 Terminal clamp sets OZXA_, OZXB_

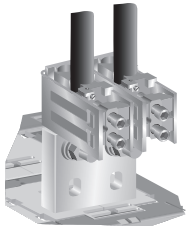

OTM2000-2500E_C_

OTM3200E_C_

OZXB3

OZXB4

OZXB5

OZXB6

OZXB7L

OTM1000-1600E_C_

OZXB3

OZXB4

OZXB5

OZXB6*

OZXB7L

OTM630-OTM800E_C_

OZXB3

OZXB4

OZXB5

OZXB6*

OZXB7L

OTM315-OTM400E_C_

OZXB2L

OZXB3

OZXB7

OZXB7L

OZXB8

OZXB9

OTM160-OTM250E_C_

OZXB1L

OZXB2

OZXB2L

OZXB8

OZXB9

OTM800-1200U_C_

OZXA-1200

OZXA-1206

* max. 1 pcs/side

OTM600U_C_

OZXA-800

OZXA-806

* max. 1 pcs/side

OTM400U_C_

OZXA-400

OZXA-406

OTM200U_C_

OZXA-200

OZXA-206

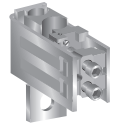

Figure 10.1 Mounting of the terminal clamp sets, types OZXB_ and OZXA_

10.2 Bridging bars OTZC_, OTZR_

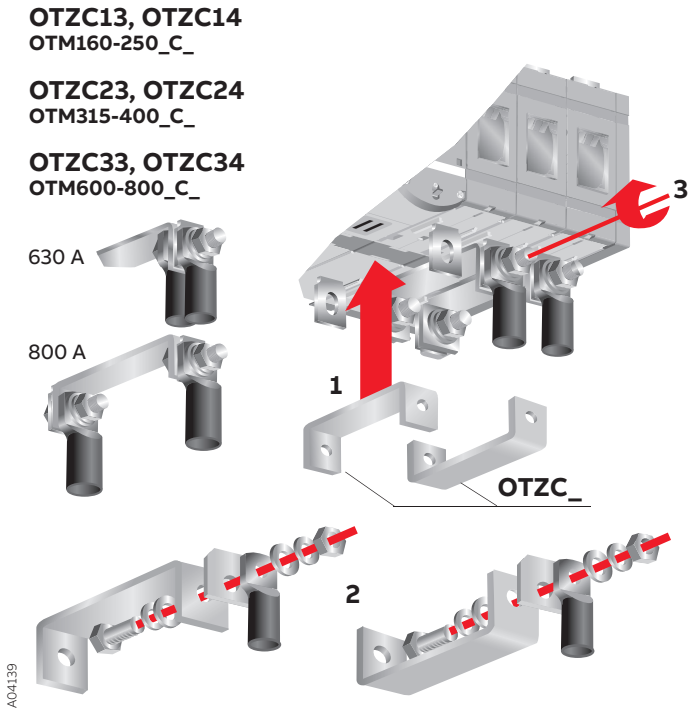
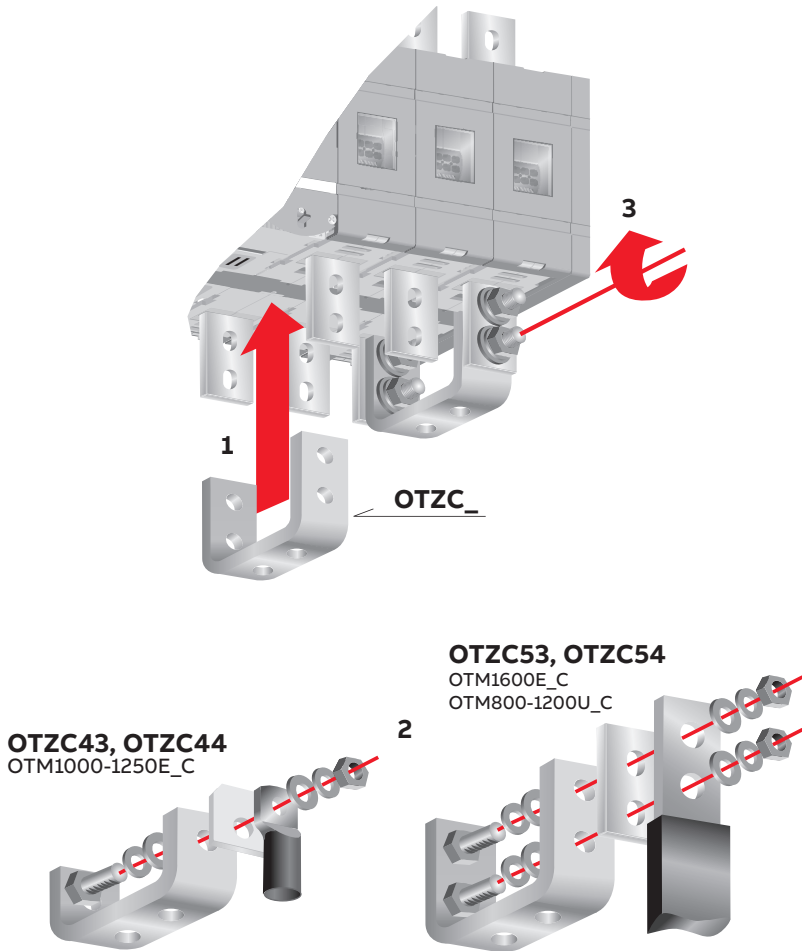

Figure 10.2 Mounting of the bridging bars (type OTZC_) to the motorized change-over switches OTM160-800E_C_



A04189

Figure 10.3 Mounting of the bridging bars (type OTZC_) to the motorized change-over switches OTM1000-1600E_C_ and OTM800-1200U_C_

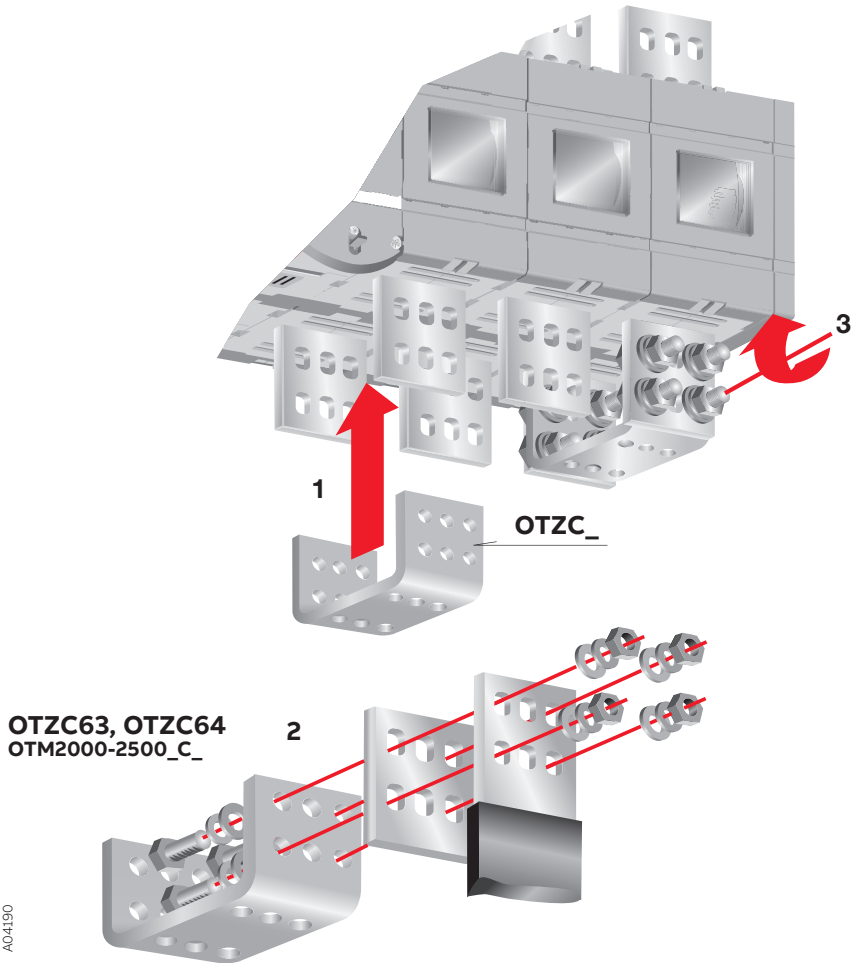

Figure 10.4 Mounting of the bridging bars (type OTZC_) to the motorized change-over switches OTM2000-2500E_C_

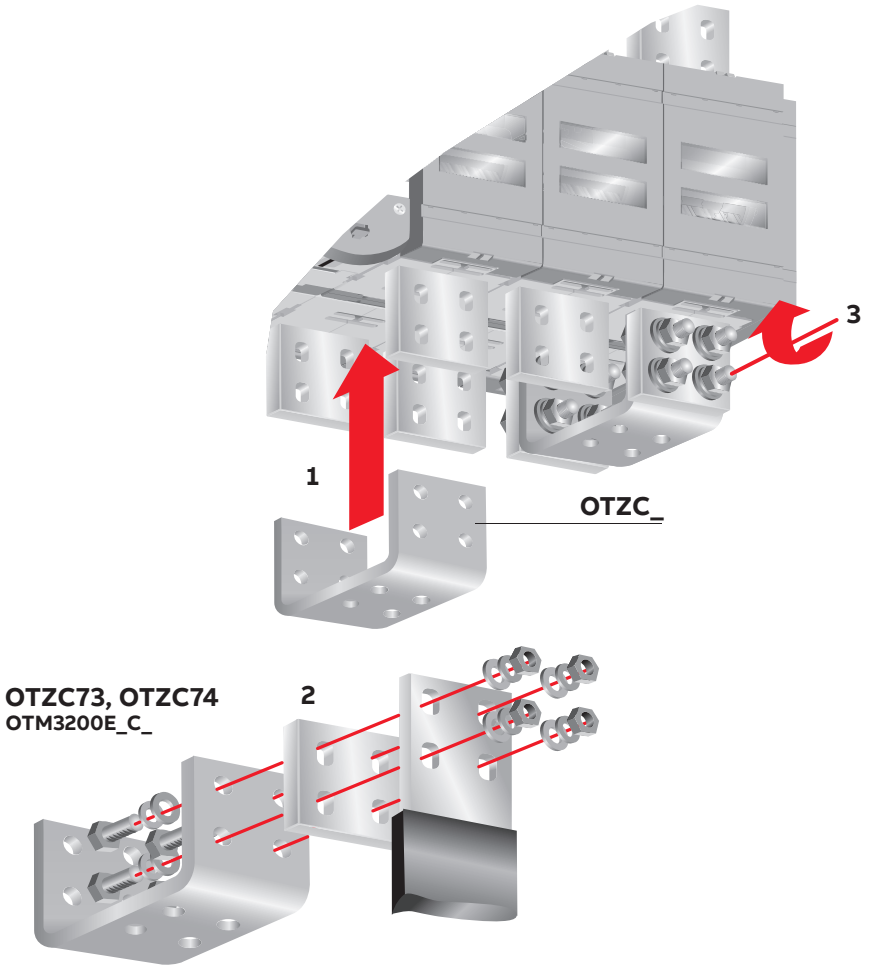

Figure 10.5 Mounting of the bridging bars (type OTZC_) to the motorized change-over switches OTM3200E_C_

10.3 Voltage sensing connectors OMZB_

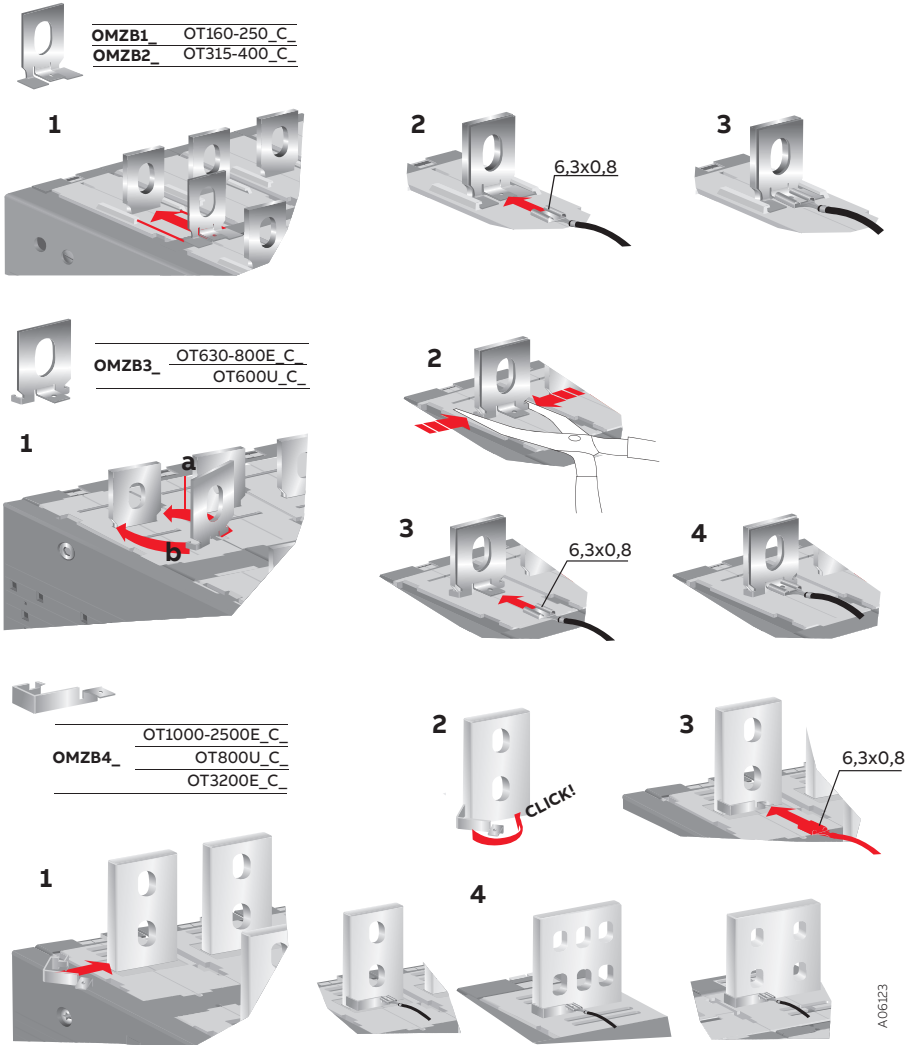

Figure 10.6 Mounting of the voltage sensing connectors, type OMZB_

10.4 Terminal shrouds OTS_

OTS250^G_{T1S}

OTS400^G_{T1S}

OTS800^G_{T1S}

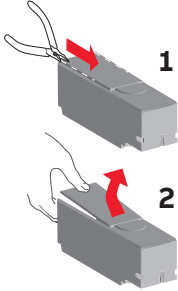

OTS250^G_{T1L}

OTS400^G_{T1L}

OTS800^G_{T1L}

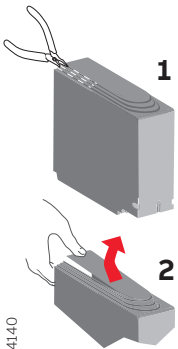

		M	M
OTM160-250_C_	OTS250_ M8	15...22 Nm	5/6 DIA in 133-195 lb.in
OTM315-400_C_	OTS400_ M10	30...44 Nm	266-390 lb.in
OTM600-800_C_	OTS800_ M12	50...75 Nm	433-664 lb.in

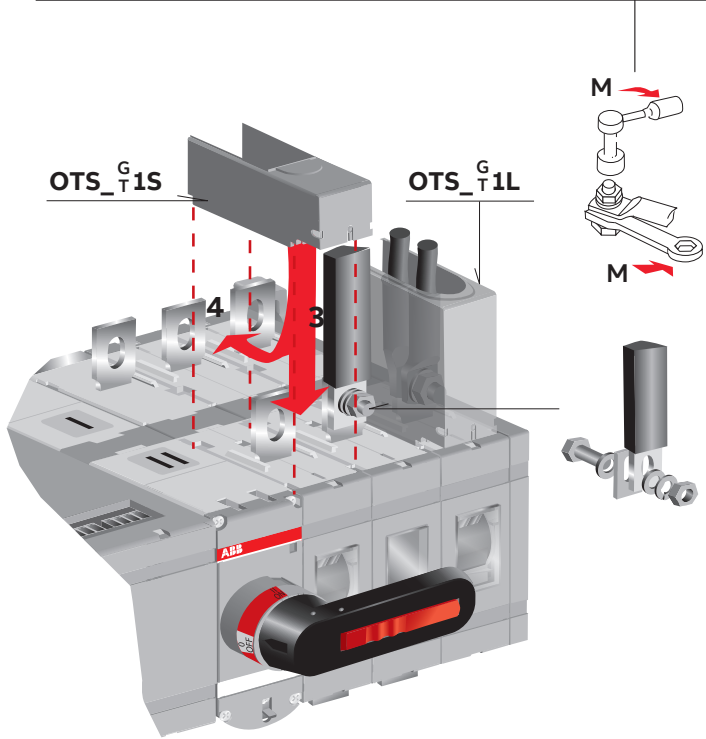

A0-41/40

Figure 10.7 Mounting of the terminal shrouds (type OTS_) to the motorized change-over switches OTM160-800E_C_

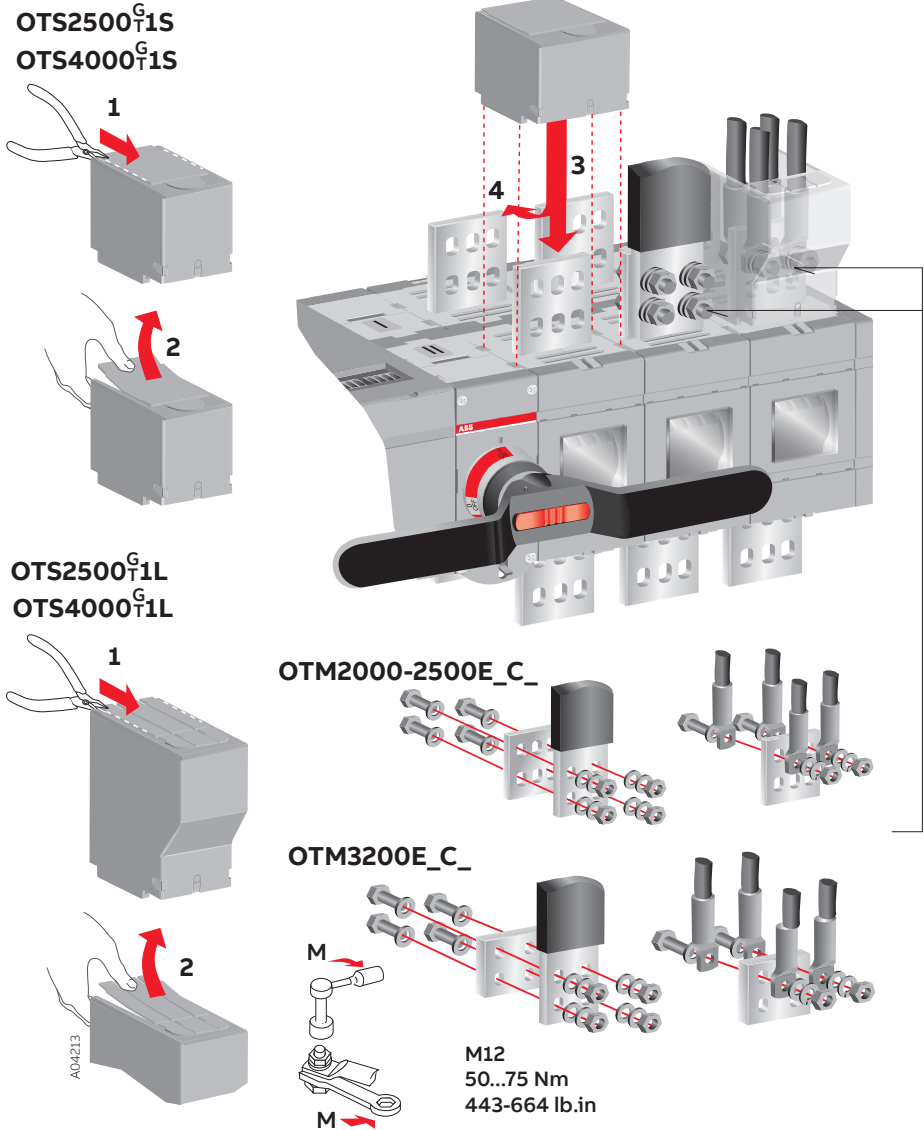
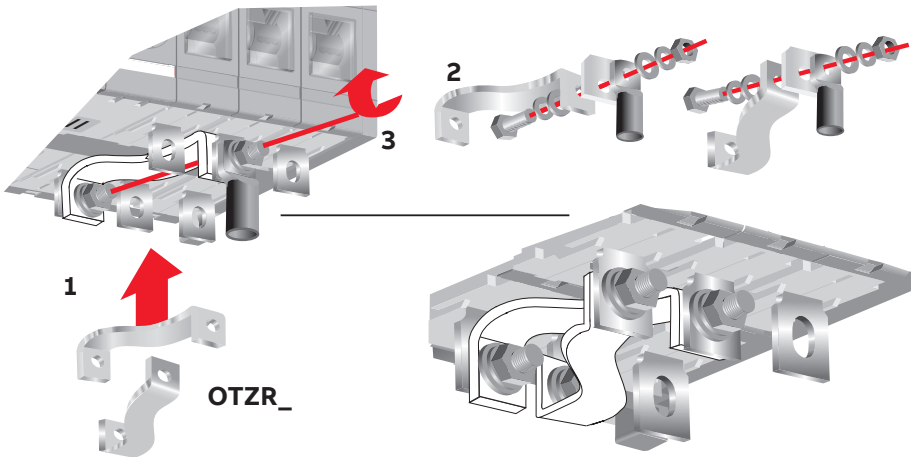

Figure 10.8 Mounting of the terminal shrouds (type OTS_) to the motorized change-over switches OTM1000-1600E_C_ and OTM800-1200U_C_

10.5 Reversing bars OTZR_

OTZR1	<u>OT_100-250_C</u>
OTZR2	<u>OT315-400_C</u>
OTZR3	<u>OT600-800_C</u>



10.6 Voltage sensing connectors OMZB_



OMZB1 OT160-250_C
OMZB2 OT315-400_C

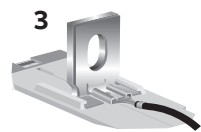
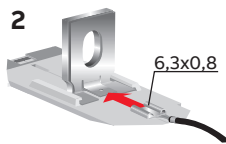
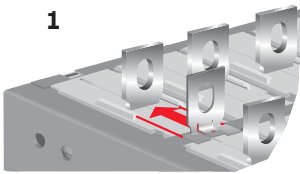

OMZB3 OT630-800E_C
OT600U_C

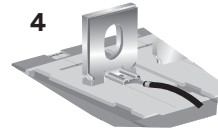
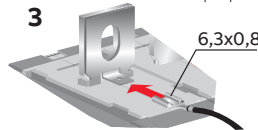
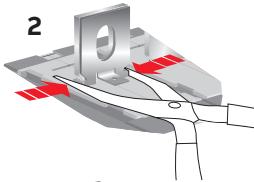
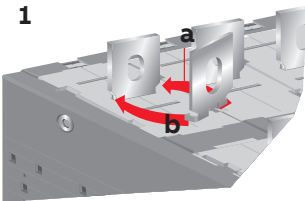

OMZB4 OT1000-2500E_C
OT800U_C
OT3200E_C

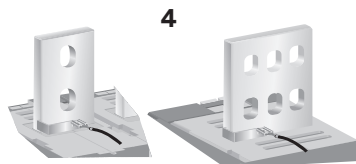
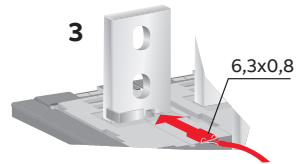
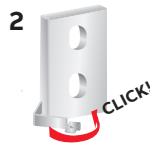
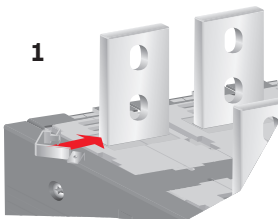

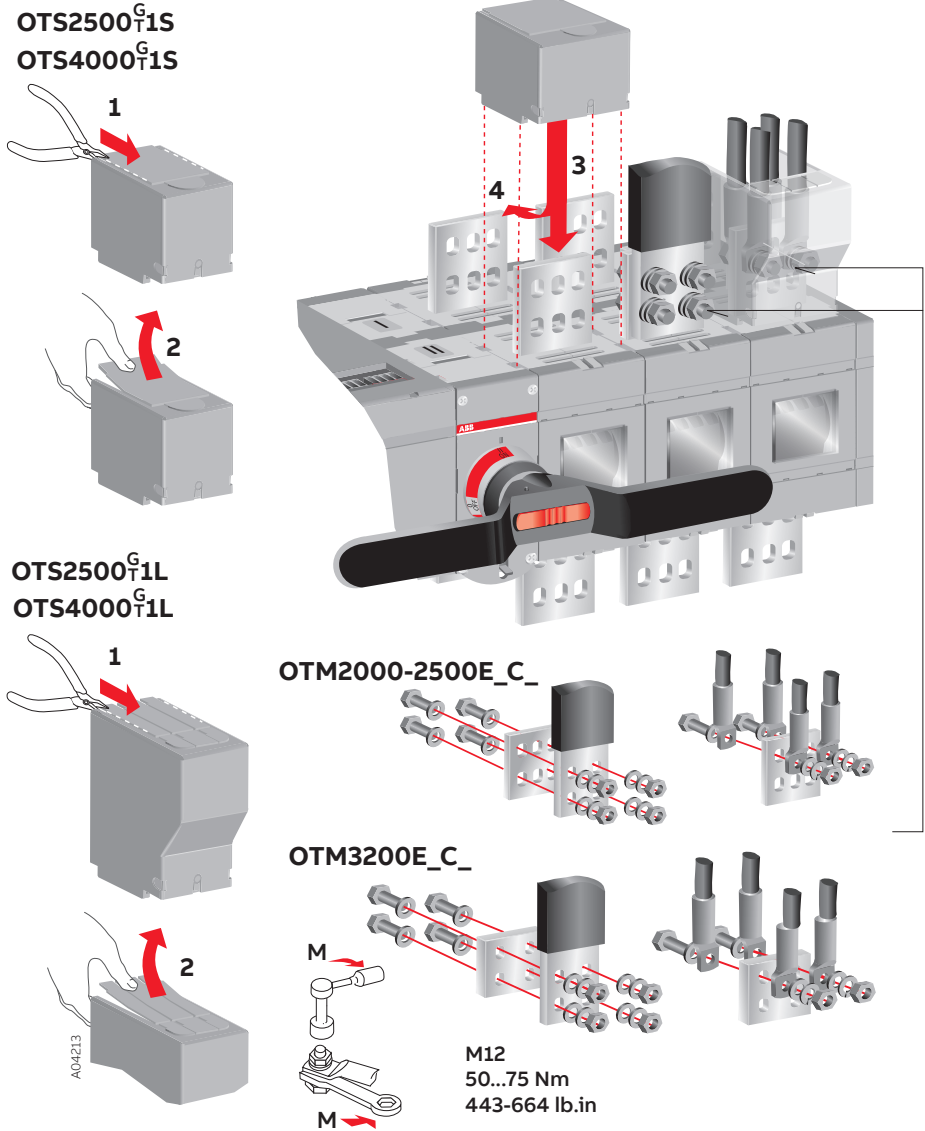

Figure 10.9 Mounting of the terminal shrouds (type OTS_) to the motorized change-over switches OTM2000-2500_C_, OTM3200_C_

10.7 Auxiliary contacts OA_

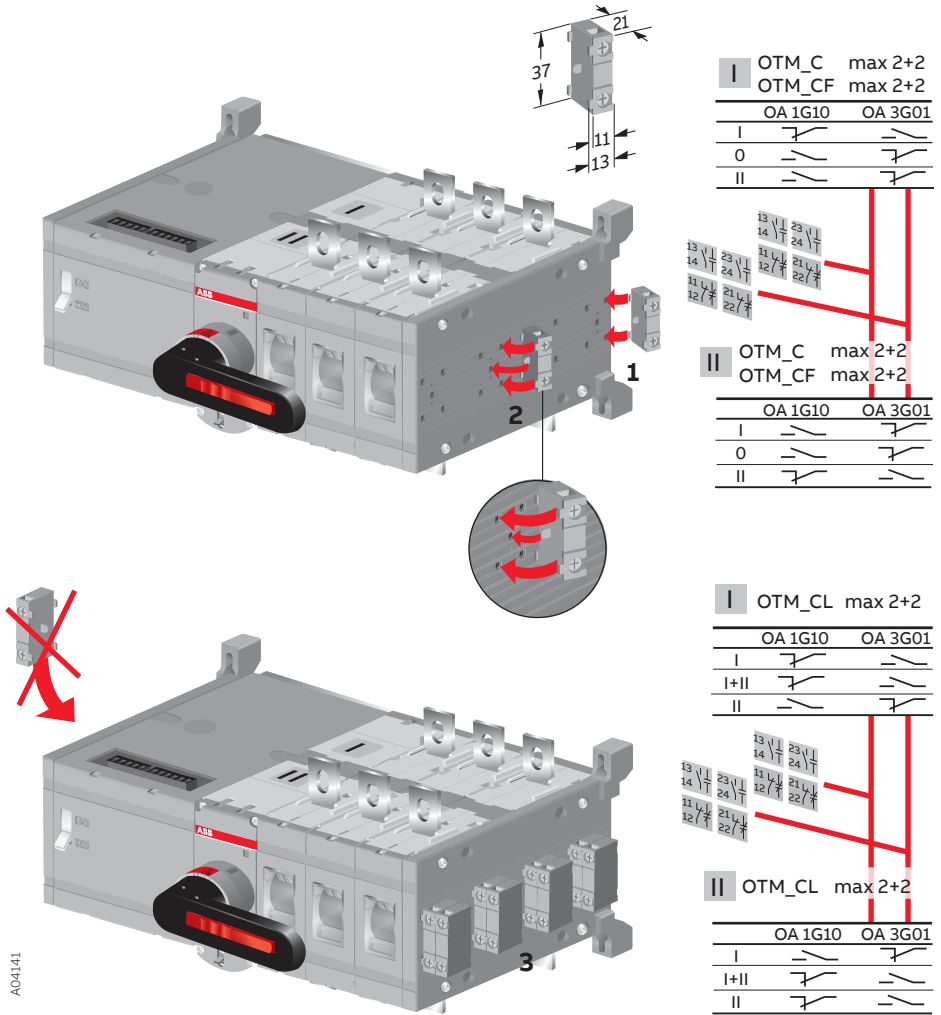
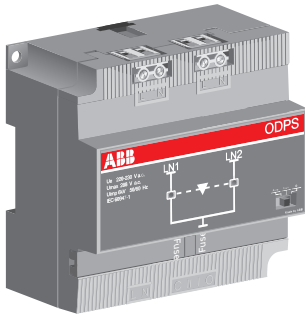

Figure 10.10 Mounting of the auxiliary contacts, type OA_

AO4141

10.8 Dual power source ODPS_



A06289

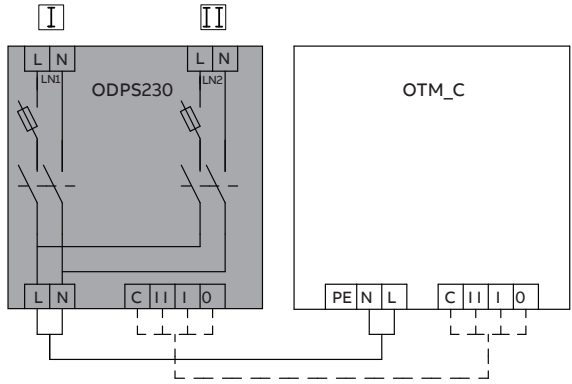
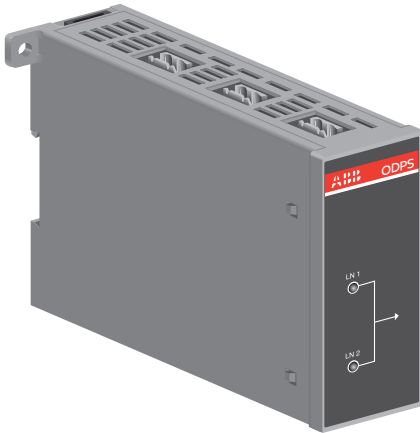

Figure 10.11 The dual power source, type ODPS230. Connection diagram ODPS230.



A06290

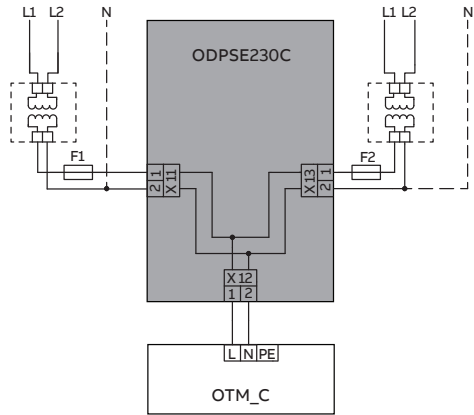
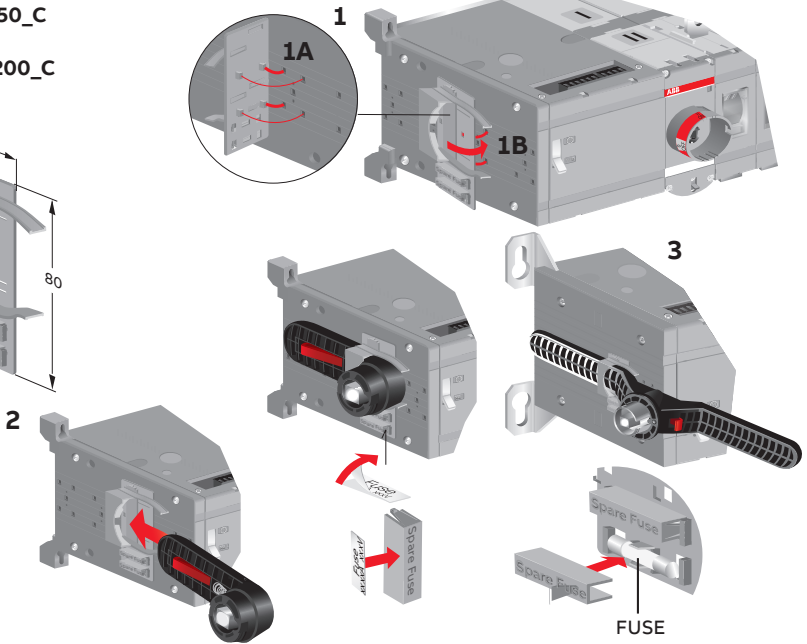
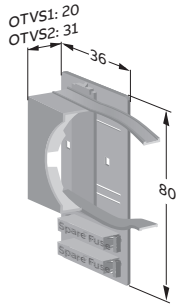

Figure 10.12 The dual power source, type ODPSE230C. Connection diagram ODPSE230C.

10.9 Handle and spare fuse storage OTVS_

OTVS1
OTM160-250_C
OTVS2
OTM315-3200_C



OTVS0
OTM160-250_C

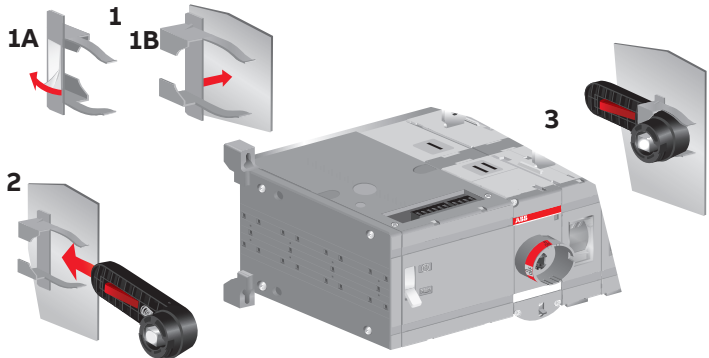
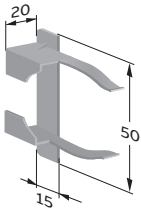

132904
A04261

Figure 10.13 Handle and spare fuses can be stored on the motorized change-over switch by mounting the accessory OTVS_

11. Clearances per UL 1008

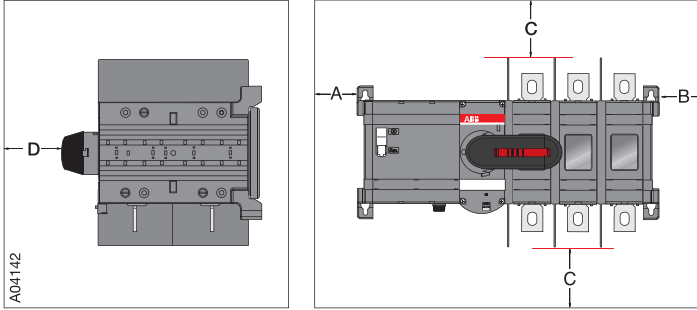

Size (Current)	A	B	D	C
OT_100-1200U_C	0	0.5 in/13 mm	0.5 in/13 mm	According to the UL1008 standard

Minimum enclosure size or equivalent volume

Size (current)	Height	Width	Depth
OTMDC100_C	6.3 in/190 mm	19 in/490 mm	12 in/315 mm
OTM200U_C	16 in/406 mm	12 in/305 mm	8 in/203 mm
OTM400U_C	24 in/610 mm	14 in/356 mm	10 in/254 mm
OTM600U_C	24 in/610 mm	28 in/700 mm	16 in/400 mm
OTM800-1200U_C	48 in/1220 mm	24 in/610 mm	16 in/400 mm

Figure 11.1 Clearances per UL 1008, minimum enclosure size or equivalent volume

11.1 Phase barriers OTB_

Phase barriers or shrouds (see section 8.3) must be used to maintain a clearance of 1 inch on the motorized change-over switch types: OTM600U_C_, if the conductors are wider than 39 mm /1.54 in (phase barrier 68838) on OTM800-1200U_C_, if the lugs are wider than 54 mm /2.13 in (phase barrier 68912).

Phase barriers 68912 must be used on motorized change-over switches types OTM1000-2500_C_ if the voltage is > 415 V Phase barriers CXBY69470 must be used on OTM3200E_C_.

The types for the package of 6 barriers are:

68838 = OTB800/6C

68912 = OTB1600/6C

CXBY69470= OTB4000/6C.

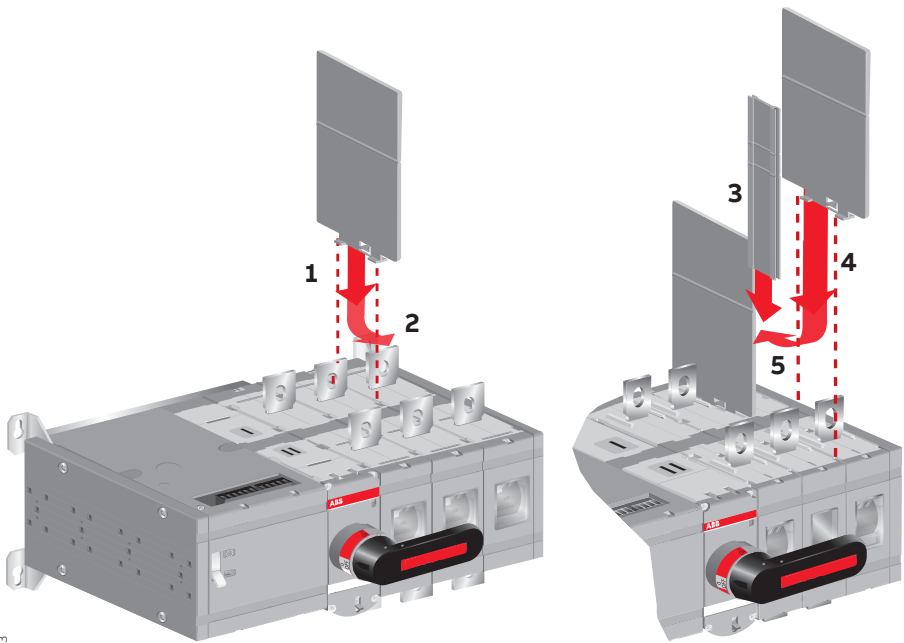

A04143

Figure 11.1 OTM600U_C_, OTM800-1200U_C_, OTM1000-2500E_C_ and OTM3200E_C_ mounting of phase barriers

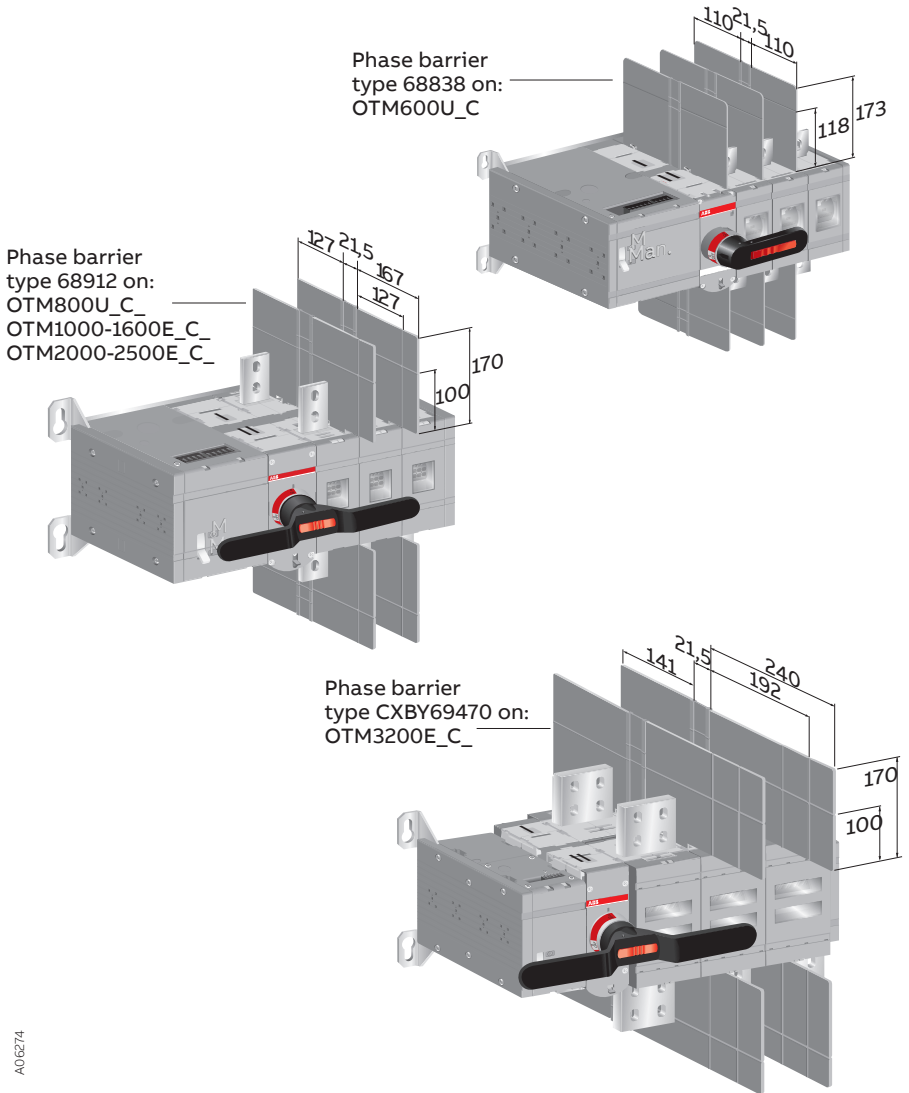

A06274

Figure 11.2 Mounting and dimensional drawings the phase barriers



BG Внимание! Опасно напряжение! Да се монтира само от лице с електротехническа квалификация.

CN 警告！电压危险！只能由专业电工进行安装。

CZ Varování! Nebezpečné napětí! Montáž smí provádět výhradně elektrotechnik!

DA Advarsel! Farlig elektrisk spænding! Installation må kun foretages af personer med elektroteknisk ekspertise.

DE Warnung! Gefährliche Spannung! Installation nur durch elektrotechnische Fachkraft.

EL Προειδοποίηση! Υψηλή τάση! Η εγκατάσταση πρέπει να γίνεται μόνο από εξειδικευμένους ηλεκτροτεχνικούς.

EN Warning! Hazardous voltage! Installation by person with electrotechnical expertise only.

ES ¡Advertencia! ¡Tensión peligrosa! La instalación deberá ser realizada únicamente por electricistas especializados.

ET Hoiatus! Ohtlik pinge. Paigaldada võib ainult elektrotehnika-alane ekspert.

FI Varoitus! Vaarallinen jännite! Asennuksen voi tehdä vain sähköalan ammattihenkilö.

FR Avertissement! Tension électrique dangereuse! Installation uniquement par des personnes qualifiées en électrotechnique.

HR Upozorenje! Opasan napon! Postavljati smije samo elektrotehnički stručnjak.

HU Figyelmeztetés! Veszélyes feszültség! Csak elektrotechnikai tapasztalattal rendelkező szakember helyezheti üzembe.

IE Rabhadh! Voltas guaiseach! Ba chóir do dhuine ag a bhfuil saineolas leictreicniúil, agus an té sin amháin, é seo a shuiteáil.

IT Avvertenza! Tensione pericolosa! Fare installare solo da un elettricista qualificato.

LT Dėmesio! Pavojinga įtampa! Dirbti leidžiama tik elektrotechniko patirties turintiems asmenims.

LV Uzmanību! Bīstami - elektrība! Montāžas darbus drīkst veikt tikai personas, kurām ir atbilstošas elektrotehniskās zināšanas.

MT Twissija! Vultaġġ perikoluż! Għandu jigi installat biss minn persuna b'kompetenza eletroteknika.

NL Waarschuwing! Gevaarlijke spanning! Mag alleen geïnstalleerd worden door een deskundige elektrotechnicus.

NO Advarsel! Farlig spenning! Montering skal kun utføres av kvalifiserte personer med elektrokompetanse.

PL Ostrzeżenie! Niebezpieczne napięcie! Instalacji może dokonać wyłącznie osoba z fachową wiedzą w dziedzinie elektrotechniki.

PT Aviso! Tensão perigosa! A instalação só deve ser realizada por um electricista especializado.

RO Avertizare! Tensiune periculoasă! Instalarea trebuie efectuată numai de către o persoană cu experiență în electrotehnică.

RU Осторожно! Опасное напряжение! Монтаж должен выполняться только специалистом-электриком.

SE Varning! Farlig spänning! Installation får endast utföras av en elektriker.





Contact us

ABB Oy

P.O. Box 622
FI-65101 Vaasa
Finland

abb.com/lowvoltage